

APPROVED TRAP

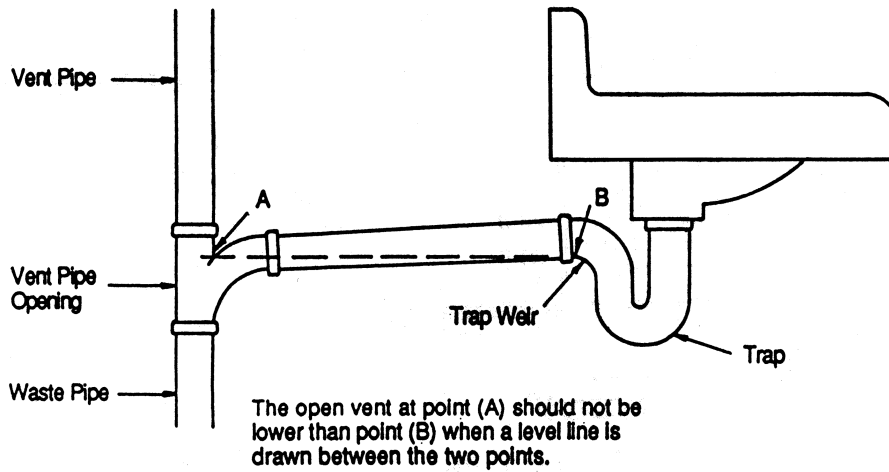

DISAPPROVED TRAPS

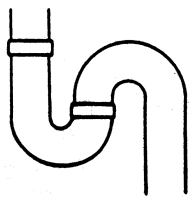

FULL S-TRAP

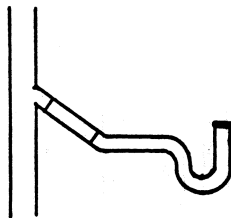

HIGH TRAP ARM

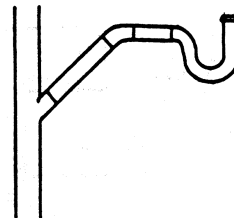

LOW TRAP ARM

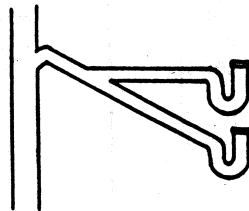

TWO TRAPS ON SAME ARM

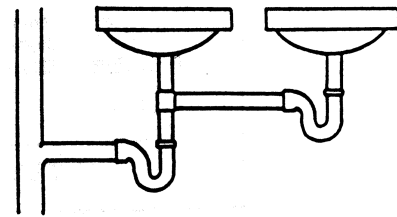

SERIAL TRAPS

INCORRECT

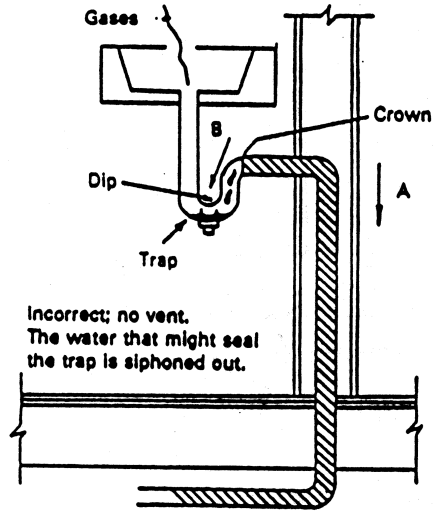
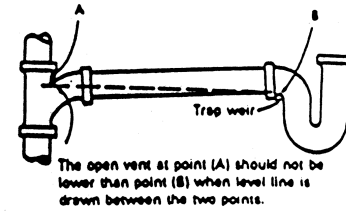

FIGURE 2202.2.1A — Example "S" Trap



CORRECT

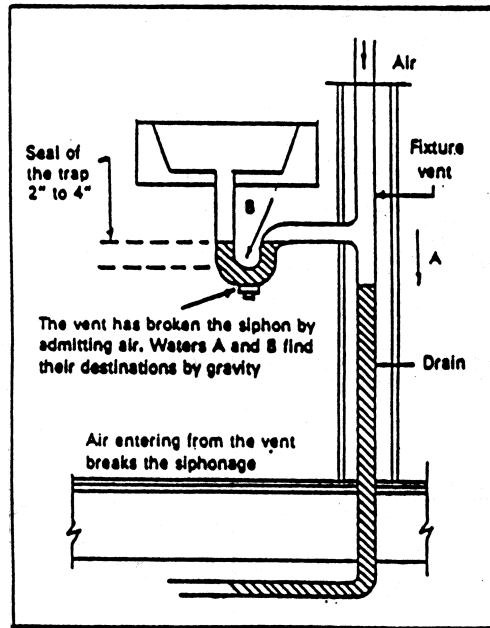

FIGURE 2202.2.1B — Example of Vented Trap

